

C7 Valve Miniature Cartridge Liquid Valve

7 mm Miniature Liquid Cartridge Valve



The Series C7 is a miniature cartridge style solenoid valve with a compact 7 mm diameter. This unique design combines small size, light weight and low power consumption with high flow repeatability and fast response time over an exceptionally long life, up to 130 million cycles. Available in 2-way configurations, the valve is manifold mounted utilizing a simple securing system reducing assembly time.

Markets

- Analytical Chemistry
- Clinical Diagnostics
- Environmental Monitoring
- Print

Applications

- Reagent Addition
- Wash
- Waste
- Flow Control
- Large format Inkjet systems

Features

- Variety of orifice sizes with pressures up to 145 PSI (10 bar).
- Floating frictionless plunger enables reliable and repeatable operation up to 130 Million cycles.
- Low power design reduces heat and energy consumption.
- Cartridge configuration enables compact integration saving space and weight.
- Simple mechanical fastening prevents valve being dislodged due to vibration or pressure spikes.
- RoHS & REACH compliant. 

Product Specifications

Mechanical

Valve Type:
Solenoid Cartridge Valve 2-Way Normally Closed (NC)
Media: Gases* and Liquids (see the details in gas datasheet)
Operating Environment:
32°F to 122°F (0°C to 50°C)
Storage Environment:
-40°F to 158°F (-40°C to 70°C)
Dimensions:
- Diameter: 0.28 in (7 mm) - Length: 0.79 in (20 mm)
Porting:
Cartridge Seal
Weight:
0.11 oz (3.1 g)
Internal Volume:
2-Way: 81µL

Orifice	0.012 in (0.3 mm)	0.020 in (0.5 mm)	0.031 in (0.8 mm)	0.039 in (1.0 mm)	
Type	2-Way	2-Way	2-Way	2-Way	
Max Vacuum & Pressure	PSI	145	116	73	43.5
	Bar	10	8	6	3
	SCCM (water)	146	260	429	415

Electrical

Voltage (VDC):
12 and 24 VDC ± 5% (Other voltages available on request.)
Electrical Connections:
3.2" (80 mm) Flying Leads [28 AWG]
Power:
Typical 0.5W - 1.2W (Please see Table 1 for more details)
Wetted Materials
Body:
Stainless Steel Series 300 and 400
Seals: (Internal and External)
FKM, EPDM

Performance Characteristics

Response:
10 ms Maximum, Cycling
Recommended Filtration:
0.3 mm Orifice 5 µm
0.5 mm, 0.8 mm, & 1.0 mm Orifice 10 µm
Reliability:
2-Way: 130 Million Cycles
0.90 Reliability Factor
95% Confidence

C7 Miniature Liquid Cartridge Valve

Flow Curve

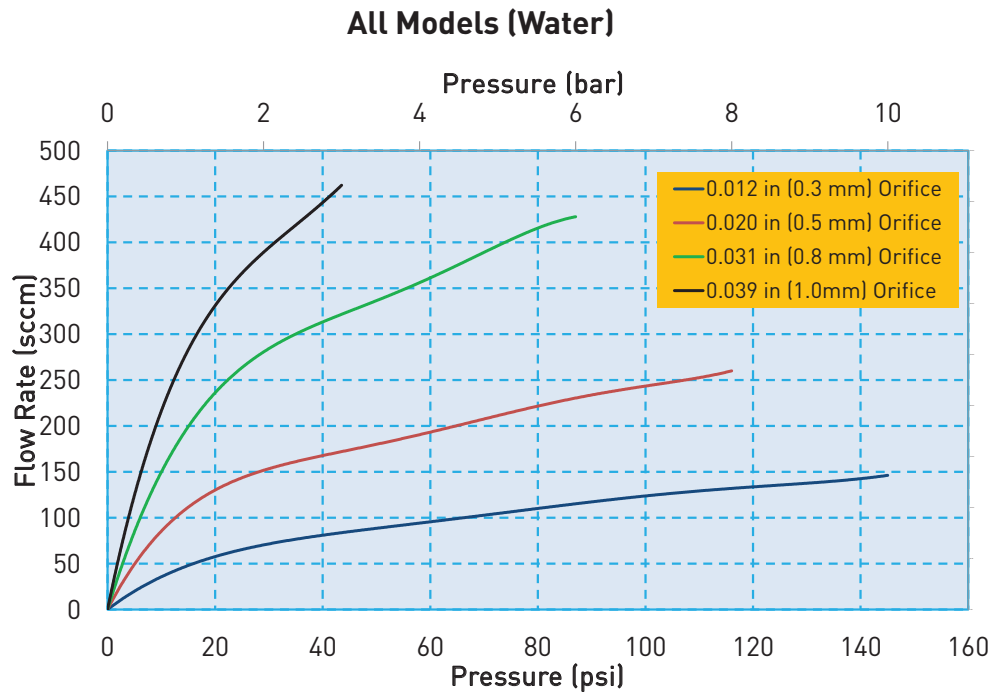

Flow Curve

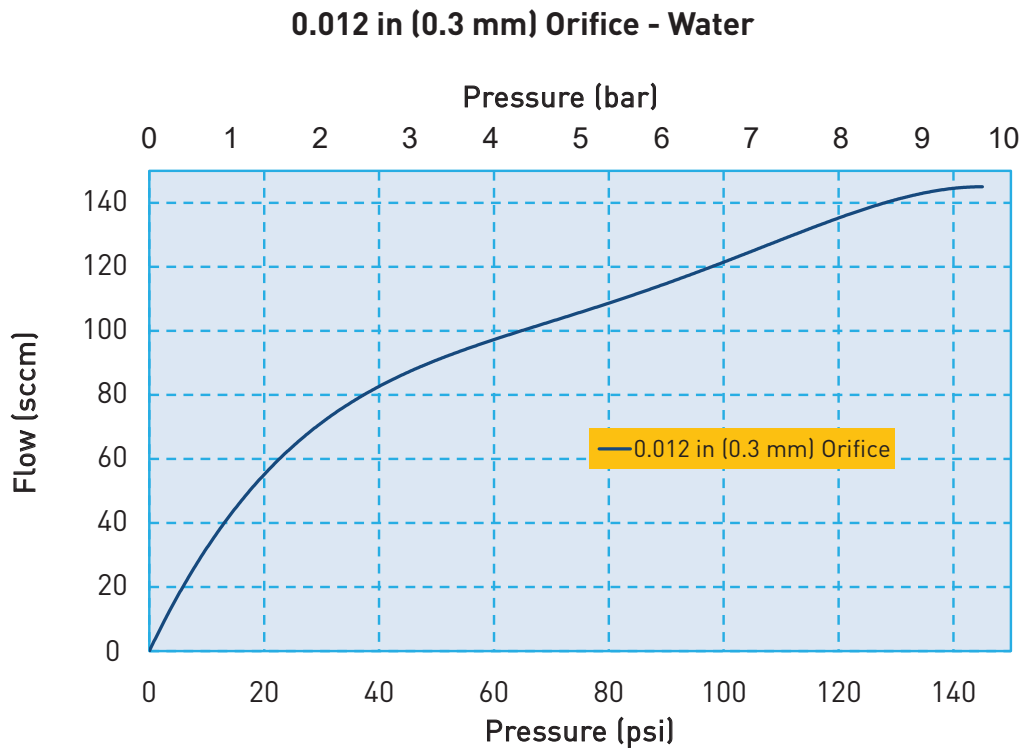

C7 Miniature Liquid Cartridge Valve

Flow Curve

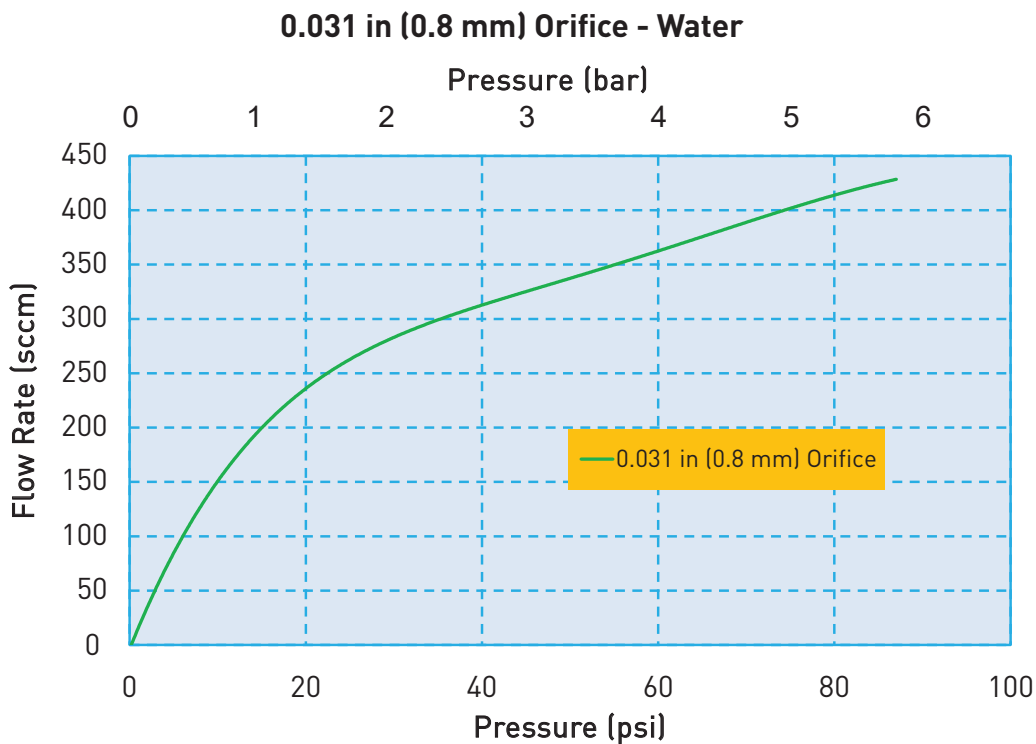
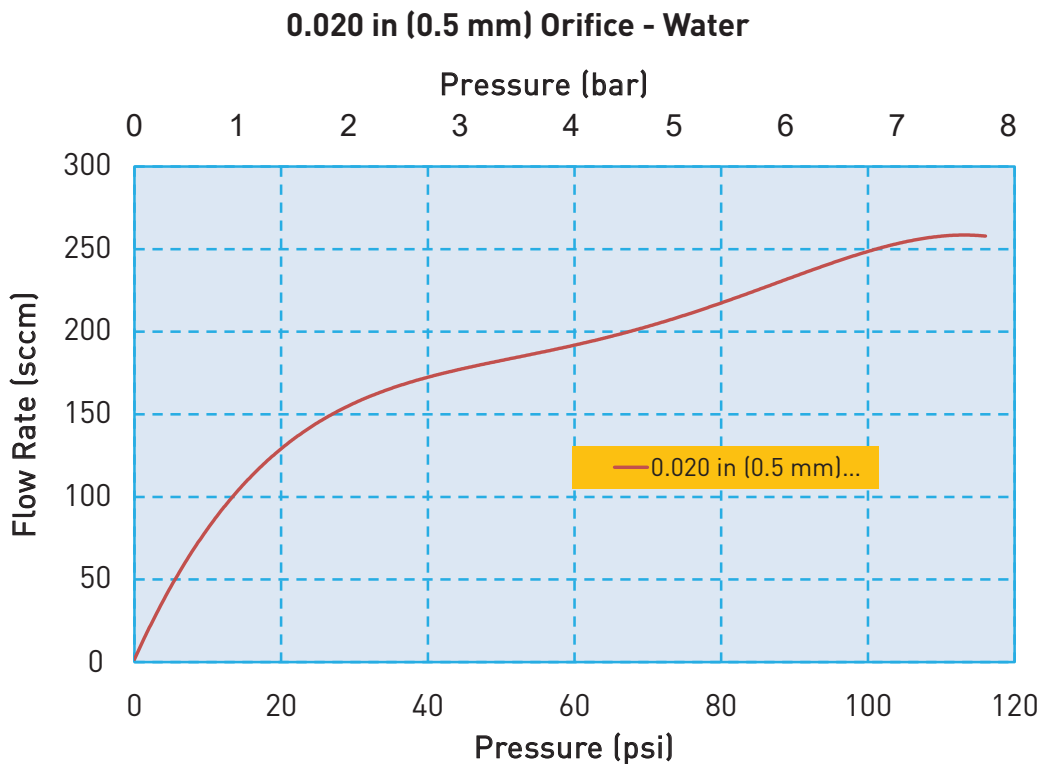

C7 Miniature Liquid Cartridge Valve

Flow Curve

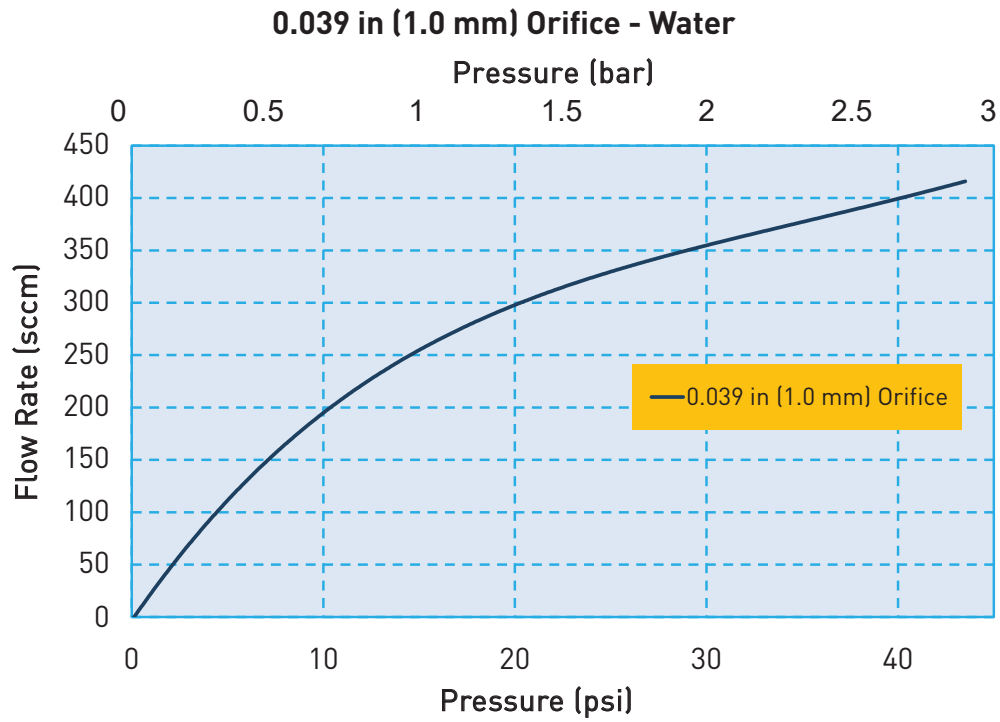

Electrical Interface



Wire Leads

Standard: 3.2 in (80 mm) Wire Leads, stripped at end

C7 Miniature Liquid Cartridge Valve

Electrical Requirements

Table 1

Orifice	0.012 in (0.3 mm)		0.020 in (0.5 mm)		0.031 in (0.8 mm)		0.039 in (1.0 mm)	
Valve Type	2-Way		2-Way		2-Way		2-Way	
Voltage (VDC)*	12	24	12	24	12	24	12	24
Power (Watts)	0.5	0.6	1	0.85	1	1.2	1	1.2
Resistance [Ohm]**	288	995	140	700	140	495	140	495
* $\pm 5\%$, other voltages available on request								
** $\pm 5\%$ @ 68°F, 20°C								

Liquid Interface/Mechanical Integration

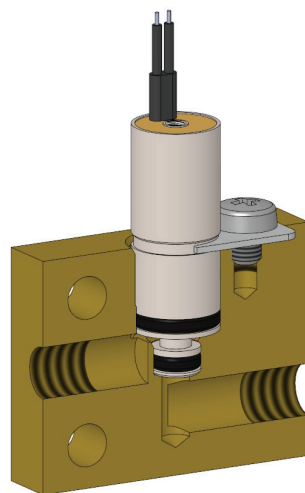

C7 Miniature Liquid Cartridge Valve

Dimensions

2-Way Valve Configuration

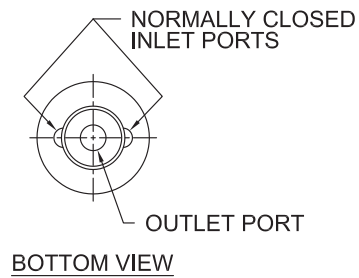
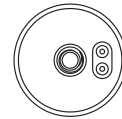
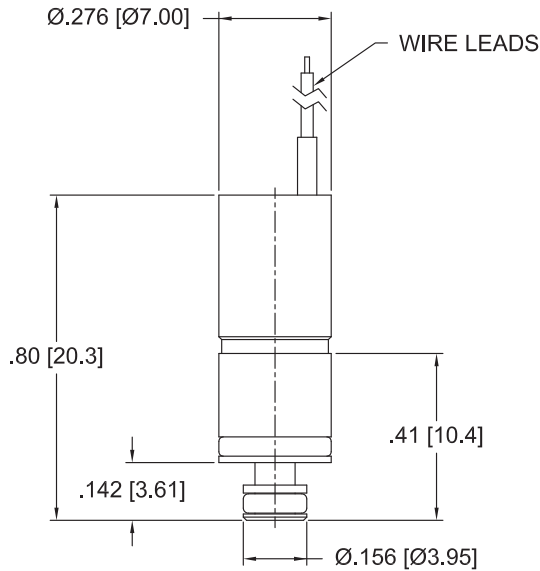

UNITS
IN [MM]

ANSI Symbols

2-Way Normally Closed

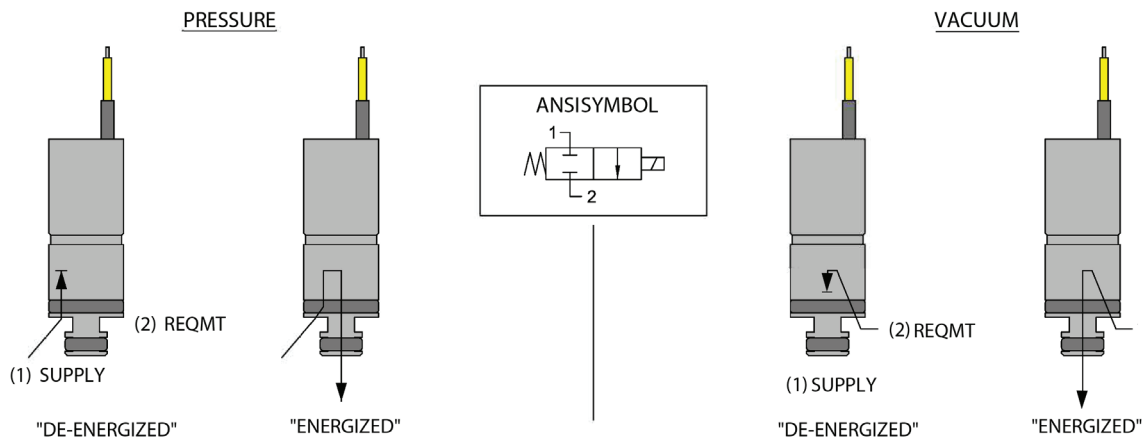

C7 Miniature Liquid Cartridge Valve

Installation and Use

During installation of the C7 valve, the maximum force allowed to press it into the manifold is: 6.74 lbf (30 N)
 Lubrication is recommended (I.E. alcohol or DI water depending on compatibility constraints)

Recommended Valve Manifold Dimensions

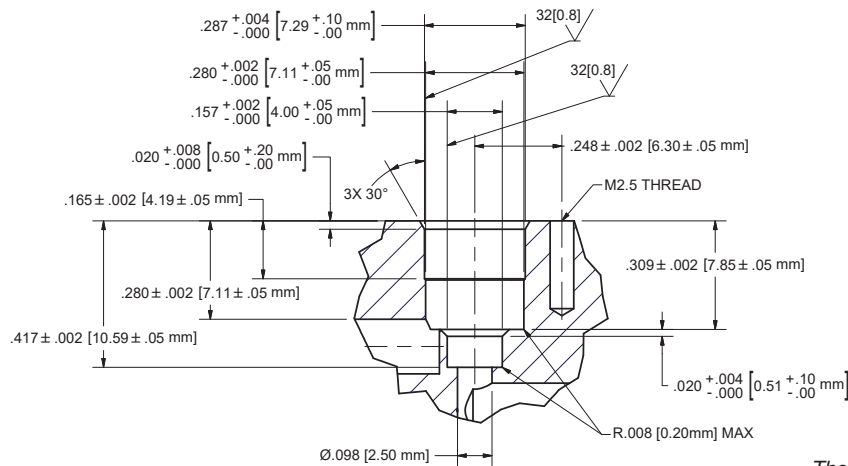

Recommended Valve Mounting

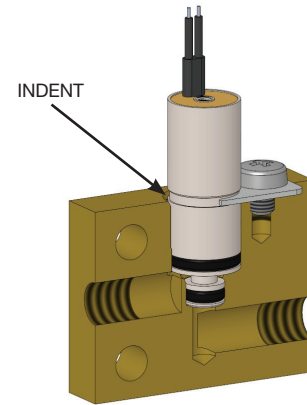

The correct location to use when holding the valve in place in the manifold is the indent at the middle of the valve body. If the top of the valve is used to hold the valve in place, the working pressure the valve will see, can push the valve upward and exceed the maximum insertion force for the valve. This could damage the valve.

Installation and Use

C7 Evaluation Manifold Dimensions and Design C07-MCS

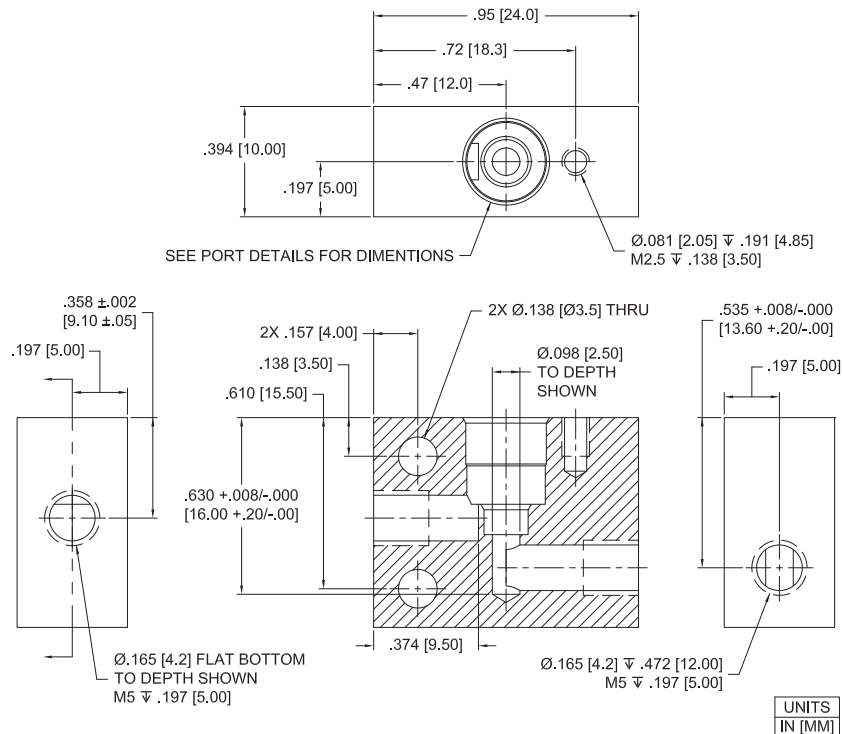

UNITS
 IN [MM]



C7 Miniature Liquid Cartridge Valve

Installation and Use

Optional Reduced Power Control Method

“Hit and Hold” is an optional control method to increase power efficiency for the C7 series valves.

Hit and Hold is a common control method used to reduce component power consumption and heat generation without sacrificing performance. The “Hit” or “Spike” state refers to the rated voltage required to actuate the valve. The “Hold” state is a substantial reduction in the rated voltage (normally 50% of the rated voltage) that maintains the valve in an actuated state.

Hit and Hold control can be incorporated using several different approaches, including discrete component circuits or programmable logic. The graph below illustrates a voltage “Hit” and “Hold” control method, however pulse width modulation (PWM) is also an acceptable control method.

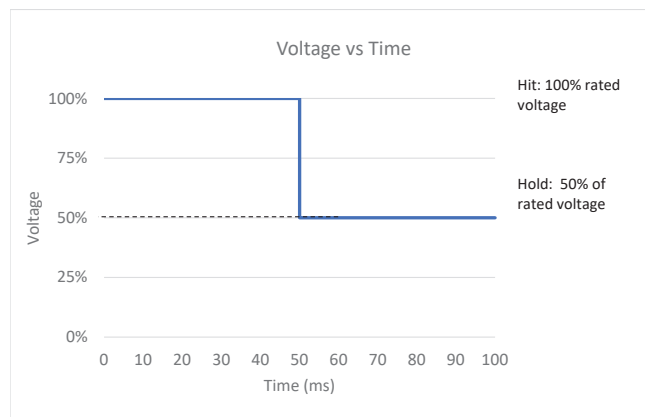

C7 Hit and Hold Specification	
Hit Voltage Level	Rated Voltage
Hold Voltage Level	50% of Rated Voltage
Minimum Hit Time	50 ms
Maximum Hit Time	N/A
PWM Frequency (Minimum)	1 kHz
Hold Nominal Duty Cycle	50%

This method greatly reduces power consumption because the valve only draws full current for a short period of time making it ideal for applications with sensitive power budgets.

Note: 50% duty cycle is a general recommendation; therefore, it is recommended that specific application testing is completed to verify the proper “hold” requirement. Factors that could impact hit and hold voltage levels include vibration, shock, pressure variation and pressure locations that are driven from specific usage. The hit and hold circuit design, combined with Parker’s valve, need to be validated for each specific application to ensure the valve will actuate under all usage conditions. **Contact Factory for more details.**

C7 Miniature Liquid Cartridge Valve

Chemical Compatibility Chart*

Chemical	Seal Options			Other Wetted Materials
	FFKM	FKM	EPDM	Stainless Steel
DI Water	1	1	1	1
Methanol	1	4	1	2
Isopropanol	1	1	1	1
Ethanol	1	3	1	1
Acetonitrile	1	4	1	
Tetrahydrofuran	1	4	4	
Toluene	1	2	4	1
MEK	4	1	1	3
Organic Acids - Dilute	1	1	1	4
Non Organic Acids - Dilute	1	1	1	2
Bases - Dilute	1	1	1	1
Saline	1	1	1	2
Bleach 12%	2	1	1	4
Sodium Hydroxide 20%	1	2	1	2

Compatibility Legend

- EXCELLENT**
Minimal or no effect
- GOOD**
Possible swelling and or loss of physical properties
- DOUBTFUL**
Moderate or severe swelling and loss of physical properties
- NOT RECOMMENDED**
Severe effect and should not be considered

*The above is an Abbreviated Chemical Compatibility Chart. Please consult factory for additional information.

Accessories

C7 Evaluation Manifold with clip and screw (Valve not included)

C07-MCS



Replacement Clip for C07-MCS

C07-C



Replacement Screw for C07-MCS

C07-S



Replacement O-Ring for C7 Valve, Large

C07-LG (FKM)
C07-LGE (EPDM)



Replacement FKM O-Ring for C7 Valve, Small

C07-SM (FKM)
C07-SME (EPDM)



C7 Miniature Liquid Cartridge Valve

Ordering Information

Sample Part ID	C07	-	2	24	FK	03	F	F	-	000
Description	Series		Configuration	Coil Voltage	Elastomer	Orifice	Mounting Style	Electrical Interface		Custom
Options	C07: 7 mm Cartridge Valve		2: 2-Way	12: 12 VDC 24: 24 VDC	EP: EPDM FK: FKM	03: 0.012 in (0.3 mm) 05: 0.020 in (0.5 mm) 08: 0.031 in (0.8 mm) 10: 0.039 in (1.0 mm)	F: Face Seal	F: 3.2 in (80 mm) flying lead		000: Standard

Accessories
<p>C07-MCS: C07 Evaluation Manifold with Clip and Screw, Not supplied with the valve.</p> <p>C07-C: Replacement Clip used on C07-MCS*</p> <p>C07-S: Replacement Screw used on C07-MCS*</p> <p>C07-LG: Spare O-Ring for C07 Valve, FKM, Large**</p> <p>C07-LGE: Spare O-Ring for C07 Valve, EPDM, Large**</p> <p>C07-SM: Spare O-Ring for C07 Valve, FKM, Small**</p> <p>C07-SME: Spare O-Ring for C07 Valve, EPDM, Small**</p> <p style="text-align: center;">* Not Supplied with Valve, Replacement Part for C07-MCS ** Supplied with Valve</p>

NOTE: For Evaluation - Please Add C07-MCS To Your Sample Order. All Valves Ship With O-Rings Installed

NOTE: In order to provide the best possible solution for your application, please provide the following requirements when contacting Applications Engineering:

- Media, Inlet & Outlet Pressures
- Minimum Required Flow Rate
- System Supply Voltage
- Media & Ambient Temperature Range



Please click on the Order On-line button to configure your C7 valve. For CAD models and more detailed information, please visit us on the Web (www.parker.com/precisionfluidics/C7_LiquidCartridgeValve), call (+1.603.595.1500) or email at ppfinfo@parker.com.

Parker Hannifin Precision Fluidics Division reserves the right to make changes. Drawings are for reference only.

For more information call +1 603 595 1500 or email ppfinfo@parker.com
 Visit www.parker.com/precisionfluidics

